

4. Wall Mounted Type (Type K2)

4-3. Dimensional Data

Indoor unit: S-15MK2E5A / 22MK2E5A / 28MK2E5A / 36MK2E5A

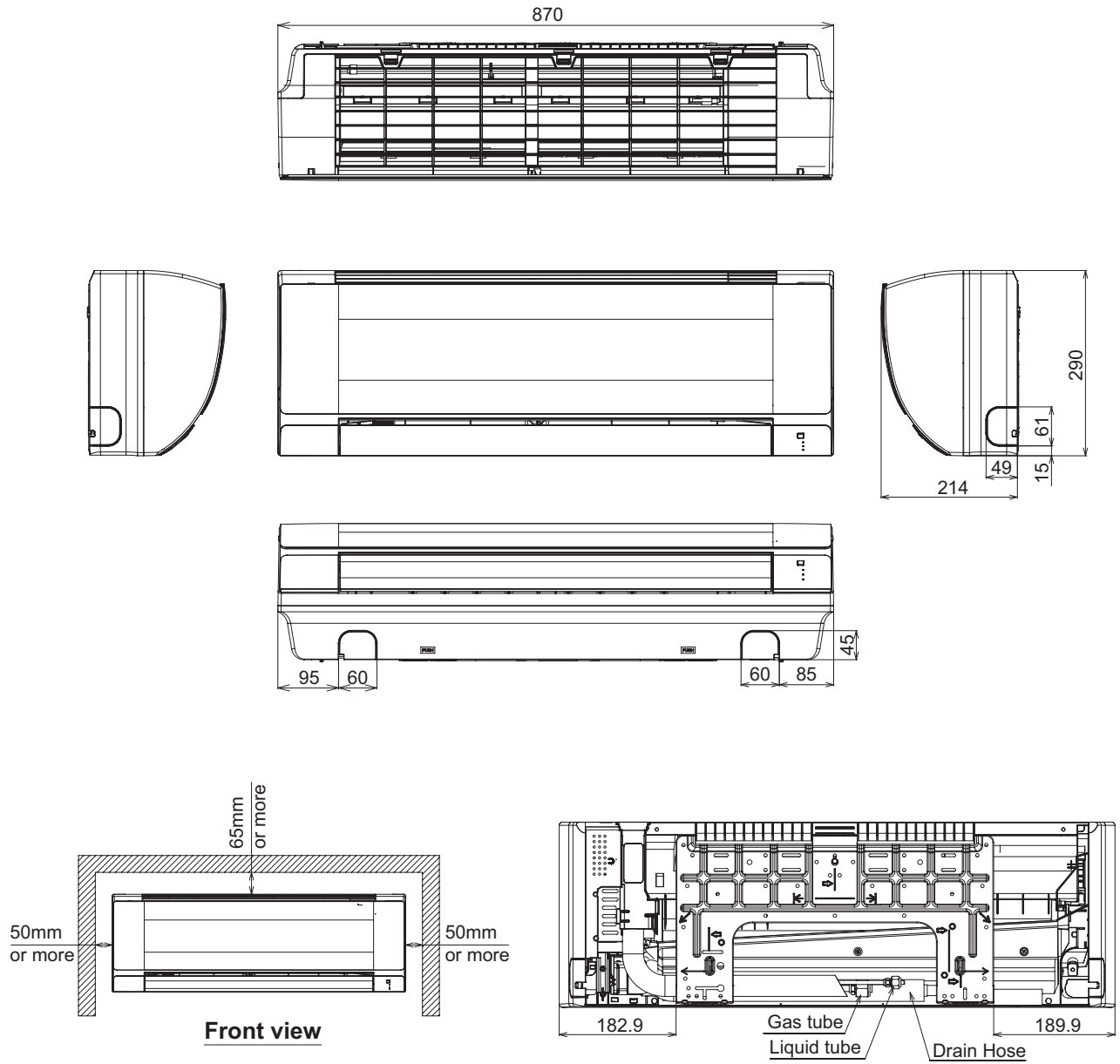

4

unit: mm

①	Refrigerant tubing (liquid tube) Ø6.35(flared)
②	Refrigerant tubing (gas tube) Ø12.7(flared)
③	Drain hose VP13 (outer dia. Ø18)
④	Rear panel (PL BACK)
⑤	Rear panel fixing holes (Ø5 holes or 5×13 oval holes)
⑥	Tubing and wiring holes (Ø70)

《 FILTER SIZE 》
(316 × 311 × 2) × 2 pcs.

